

11 | MACHINING SERVICES

Machining your TSLOTS is an alternate way of assembling your project. Rather than using brackets and joining plates you can have your TSLOTS machined and ready in kit form for quick assembly.

Machining Services

MACHINING SERVICE

There are 8 standard machining services, they are as follows:

- Cut to Length
- Tap Profile End
- Drill Access Hole
- Counterbore Anchor/Butt Fastening Assembly
- Counterbore for Miter Cuts
- Plastic/Wire Cut to Length
- Panel Notch for Profile/Fastener Clearance
- Deluxe Door Handle Milling Service

To make machining TSLOTS a simple, straightforward process, it is necessary to identify the machinable location of the extrusion. For standard services, refer to the drawings on this page for basic identification of each profile.

The machining section will detail each type of standard machining service so you can properly identify what you need done to your TSLOTS, either in our facility or yours.

Some things to keep in mind when ordering machining services:

If you order TSLOTS extrusions that are less than stocked length (20'), make sure the quantity of cut to length services matches the number of TSLOTS ordered. Where possible, include a drawing with the required machining services.

Remember, if you have us machine your kit for you, it will arrive at your door ready to assemble. Or, if you prefer, we will ship your kit to you pre-assembled, ready to use.

For non-standard machining services, custom prints are required or engineering help is available.

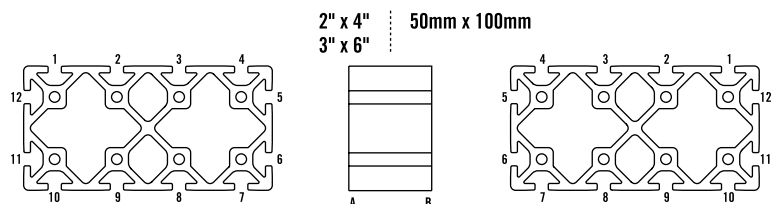
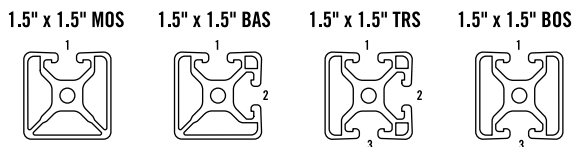
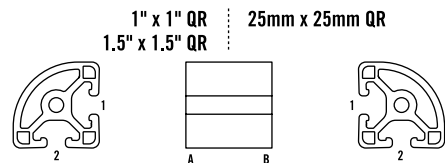
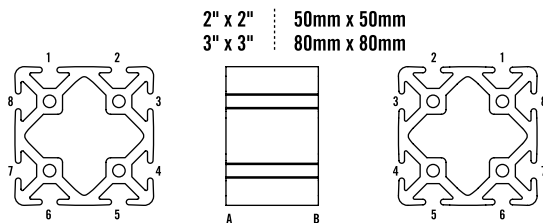
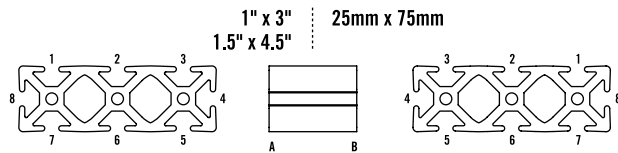
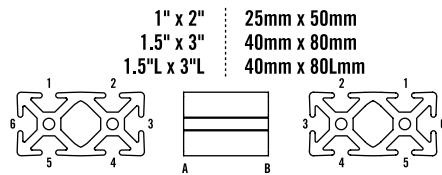
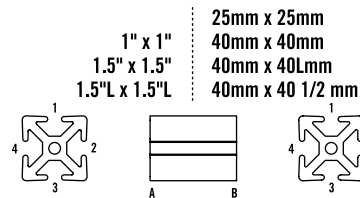

ORDERING NOTES

CUT TO LENGTH

Specify –

1. The extrusion item number or description
2. The machining service number
3. The length of the extrusion
4. The quantity of extrusions

TAPPING

Specify –

1. The extrusion item number or description
2. The number of pieces to be tapped
3. The machining service number
4. The end(s) at which the tapped hole is required
5. The length of the extrusion

DRILL ACCESS HOLES

Specify –

1. The extrusion item number or description
2. The number of pieces to be drilled
3. The machining service number
4. The T-Slot location at which the feature is required and the distance from end "A"
5. The length of the extrusion

COUNTERBORE FOR ANCHOR/BUTT FASTENER ASSEMBLY

Specify –

1. The extrusion item number or description
2. The number of pieces to be counterbored
3. The machining service number
4. The end(s) to be machined and the T-Slot location at which the counterbore is required
5. The length of the extrusion

MITER CUT AND COUNTERBORE

Specify –

1. The extrusion item number or description
2. The number of pieces to be miter cut
3. The machining service number
4. The end(s) at which the machining is required and the face from which a bolt would be installed
5. The length of the extrusion from longest corner to longest corner

All other machining services have ordering notes and ordering examples on the page where the machining service is located.

Machining Services

ORDER EXAMPLE

Your project calls for 15 pieces of 1.5" x 1.5" extrusion and 5 pieces of 1.5" x 3". All 15 pieces of the 1.5" x 1.5" are cut to length and will be machined – 10 pieces @ 55" and 5 pieces @ 24.25" and all 5 pieces of the 1.5" x 3" are miter cut and counterbored – 5 pieces @ 16.35".

In this example there are (3) separate orders that will take place:

- I. 10 pieces of 1.5" x 1.5" @ 55"
- II. 5 pieces of 1.5" x 1.5" @ 24.25" and
- III. 5 pieces of 1.5" x 3" @ 16.35".

**At the end of your machining order, total each machining service on separate lines.
Ex. In Scenario I and II there are 15 Cut To Length charges – 660003 – 15.

The information needed to complete the above order scenario is as follows:

- I. The 10 pieces of 1.5" x 1.5" @ 55":
 - 1a. Extrusion item number or, Description pieces, length
 - 2a. Tapped
 - 3a. Drilled for access holes
- II. The 5 pieces off 1.5" x 1.5" @ 24.25":
 - 1b. Extrusion item number or Description, pieces, length
 - 2b. Tapped
 - 3b. Counterbored
- III. The 5 pieces of 1.5" x 3" @ 16.35":
 - 1c. Extrusion item number or Description, pieces, length
 - 2c. Miter cut and counterbored

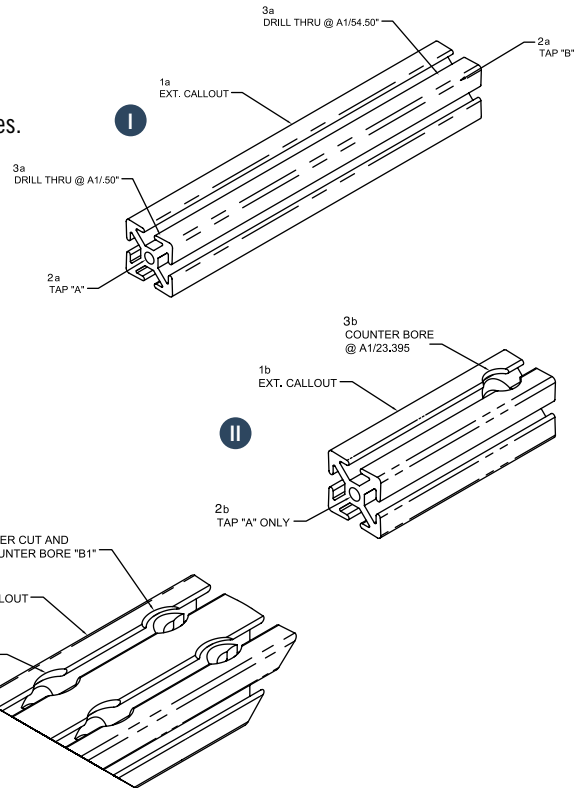

Your order would look as follows:

ITEM #	QTY	MACHINING SERVICE NUMBER	LENGTH
I. (1a) 650005 (TS1515)	10	(2a) 660034 A-B (3a) 660028 A1/.75"-A1/54.25"	55"
II. (1b) 650005 (TS1515)	5	(2b) 660034 A (3b) 660057 A1/23.395"	24.25"
III. (1c) 650008 (TS1530)	5	(2c) 660056 A1-A2--B1-B2	16.35"
Machining Services Details	15	660003	
	25	660034	
	20	660028	
	5	660057	
	10	660056	

CUT TO LENGTH



ITEM #	DESCRIPTION - 10 S / 25 S
660002	Cut To Length 1010, 1010-QR / 2525, 2525-QR
660000	Cut To Length 1020 / 2550
660004	Cut To Length 2020 / 5050
660001	Cut To Length 1030 / 2575
660005	Cut To Length 2040 / 50100

ITEM #	DESCRIPTION - 15 S / 40 S
660003	Cut To Length 1515, 1515-L, 1515-QR / 4040, 4040-L, 4040-VL
660006	Cut To Length 1530, 1530-L / 4080, 4080-L, 4080-VL
660007	Cut To Length 1545
660013	Cut To Length 3030 / 8080
660008	Cut To Length 3060
660129	Miscellaneous Cut Charge

- Tolerance on cuts is +/- .015"
- Squareness of cut is .002" per inch max.

ORDERING NOTE

Cut to length requirements should be described by specifying:

1. The extrusion Item number, pieces and length
2. The number of pieces
3. The machining service number
4. The length of the extrusion.

EXAMPLE

A project required 8 pieces of 1.5"x1.5", cut to a length of 60" each.

These profiles would be ordered as follows:

ITEM #	QTY	MACHINING SERVICE NUMBER	LENGTH
650005 (TS 1515)	8		60"
	8	660003	

Machining Services

TAP PROFILE END



This machining service provides one or more tapped holes to your extrusion ends. End tap holes are required for the following fastening and accessories when using extrusion end.

- End Fastener Assembly
- Leveling Feet
- Base Plates
- Anchor Plates
- Caster Mounting Plates
- Pressure Manifold Plates
- Casters

ITEM #	# OF TAPS	DESCRIPTION - 10 S / 25 S
660035	1	1/4-20 Tap For 1010, 1010-QR
660036	1	M6 Tap For 1010, 1010-QR / 2525, 2525-QR
660025	2	1/4-20 Tap For 1020
660026	2	M6 Tap For 1020 / 2525
660037	4	1/4-20 Tap For 2020
660040	4	M6 Tap For 2020 / 5050
660016	3	1/4 Tap For 1030
660017	3	M6 Tap For 1030 / 2575
660018	4	1/4 Tap For 2040
660019	8	M6 Tap For 2040 / 50100

ITEM #	# OF TAPS	DESCRIPTION - 15 S / 40 S
660015	1	1/8 NPT Tap For 1515, 1515-L, 1515-QR / 4040, 4040-L, 4040-VL
660034	1	5/16-18 Tap For 1515, 1515-L, 1515-QR / 4040, 4040-L, 4040-VL, 2525
660033	1	M8 Tap For 1515, 1515-L, 1515-QR / 4040, 4040-L, 4040-VL, 2525
660009	1	3/8-16 Tap For 1515, 1515-L, 1515-QR / 4040, 4040-L, 4040-VL
660030	1	7/16-14 Tap For 1515, 1515-L, 1515-QR / 4040, 4040-L, 4040-VL
660024	2	5/16-18 Tap 1530 & 1530-L / 4080, 4080-L, 4080-VL, 2550
660027	2	M8 X 1.25 Tap For 1530 & 1530-L / 4080, 4080-L, 4080-VL, 2550
660010	3	5/16-18 Tap For 1545
660011	3	M8 X 1.25 Tap For 1545
660031	4	5/16-18 Tap For 3030 / 8080
660032	4	M8 X 1.25 For 3030 / 8080
660012	8	5/16-18 Tap For 3060
660014	8	M8 X 1.25 For 3060

» *Non-standard machining services are quoted by Futura Industries*

ORDERING NOTE

Profile end tapping requirements should be described by specifying:

1. The extrusion Item number or Description
2. The number of pieces
3. The machining service number
4. The end(s) at which the tapped hole is required
5. The length of the extrusion

See page 11:02 for the drawings of the extrusion ends.

EXAMPLE

You want 4 pieces of the 1.5" x 1.5" @ 30" tapped at each end for the attachment of the 5/16-18 End Fastener Assembly. This machining service would be ordered as follows:

ITEM #	QTY	MACHINING SERVICE NUMBER	LENGTH
650005 (TS1515)	4	660034 A-B	30"
	4	660003	
	8	660004	

◦ 1/4-20 Tap is standard for 10 Series

◦ 5/16-18 Tap is standard for 15 Series

DRILL ACCESS HOLE



ITEM #	DESCRIPTION
660029	10 S / 25 S Single Drill Access Hole .218 thru
660028	15 S / 40 S Single Drill Access Hole .295 thru
660105	10 S Two-hole Pattern in-line on a single T-Slot .218 thru
660106	15 S Two-hole Pattern in-line on a single T-Slot .295 thru
660107	10 S Two-hole Pattern side by side on a double T-Slot .218 thru
660108	15 S Two-hole Pattern side by side on a double T-Slot .295 thru
660159	10 S 3-Hole Pattern side by side on a 10 x 30 .218 thru
660109	15 S 3-Hole Pattern side by side on a 15 x 45 .295 thru - Needs a 10 S 3 Hole
660110	10 S 4-Hole Pattern .218 thru
660111	15 S 4-Hole Pattern .295 thru

10 SERIES / 25 SERIES

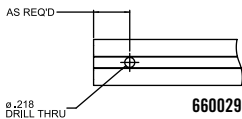

15 SERIES / 40 SERIES

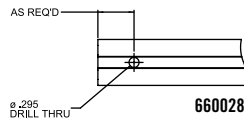

10 SERIES

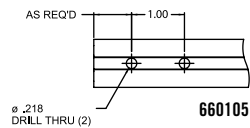

15 SERIES

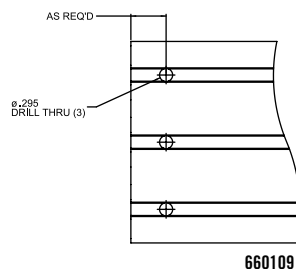
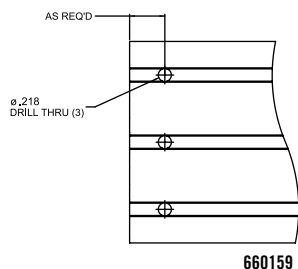
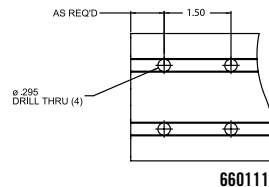
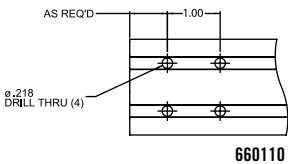
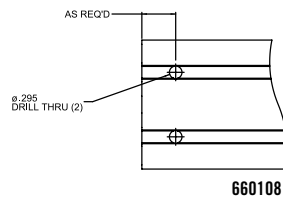
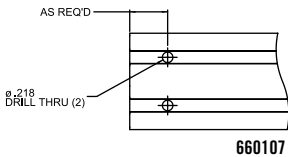
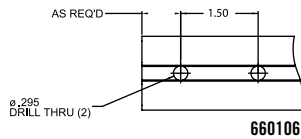

ORDERING NOTE

Access hole requirements should be described by specifying:

1. The extrusion Item Number or Description to be machined
2. The quantity of pieces to be machined
3. The machining service number
4. The T-Slot(s) location at which the drilling is required and the distance from the end "A"
5. The length of the extrusion.

If multiple single hole drillings are required on one profile, they should be called out together with a hyphen (-) separating each drilling location callout. If different access hole drilling services are required on one profile (i.e. 1 x single hole, 1 x 4-hole pattern), they should be called out as separate line items. See page 11:02 for the correct end and T-Slot location call-outs.

EXAMPLE

You want 2 pieces of 1.5 x 1.5" @ 45" to receive a two-hole inline access hole pattern at both ends, for attachment of a length of 15 x 30. The order would look as follows:

ITEM #	QTY	MACHINING SERVICE #	LENGTH
650005 (TS 1515)	2	660106 A1/.75"-A1/44.25"	45"
	2	660003	
	4	660106	

Note that the distance specified in both cases (from the reference end of the profile) will provide a flush connection with the mating extrusion.

The 10 Series access hole is a .218 drill thru, the 15 Series access hole is a .295 drill thru that are required any time an end fastening assembly is used. The drill thru allows access for tightening the button head screw used in the fastening set.

Machining Services

COUNTER BORE WITH THROUGH HOLE



ITEM #	DESCRIPTION
660139	15 S .344 Drill Through .531 Spot
660168	10 S .266 Drill Through .438 Spot

DELUXE DOOR HANDLE MILLING SERVICE



ITEM #	DESCRIPTION
660086	Deluxe Door Handle Milling Service

ORDERING NOTE

When ordering this service, specify the extrusion to be used and the distance from the end of the extrusion where the milling should take place. See page 11:07 for correct T-Slot call-out.

EXAMPLE

A project requires that a deluxe door handle be used on a 15 x 15 extrusion. The door handle will be 8" from side "A" in T-Slot 4. The machining service would look as follows:

ITEM #	QTY	MACHINING SERVICE #	LENGTH
650005 (TS1515)	1	660086 A4/8"	24"

- Milling the extrusion allows the deluxe door handle to be mounted to the T-SLOTS extrusion.
- Please specify distance from end to handle center.
- Deluxe door handle is on page 6:07.

» *For 15 Series only.*

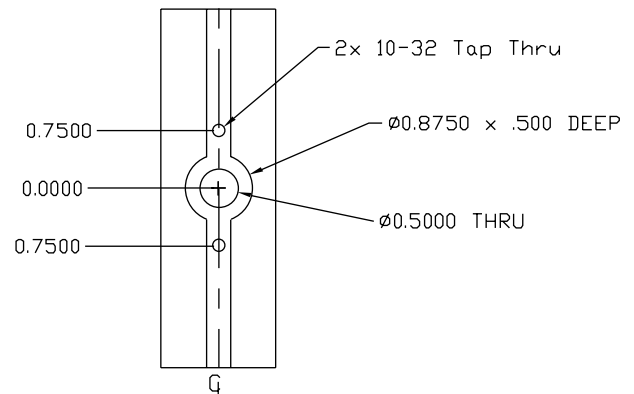

ANCHOR FASTENER / BUTT FASTENING ASSEMBLY



ITEM #	DESCRIPTION
660020	15 S / 40 S Anchor Fastener Counterbore
660022	10 S / 25 S Anchor Fastener Counterbore
660021	15 S / 40 S Butt Fastener Counterbore
660023	10 S / 25 S Butt Fastener Counterbore

- Counterbore is needed to insert the anchor fastener assembly or butt fastener assembly
- Counterbore locations for each extrusion must be specified as shown below.
- Anchor fasteners & butt fasteners are on page 4:07.

ANCHOR FASTENING

10 SERIES / 25 SERIES

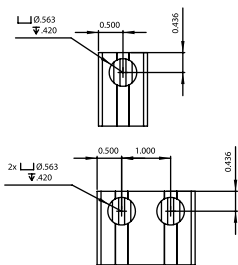

15 SERIES / 40 SERIES

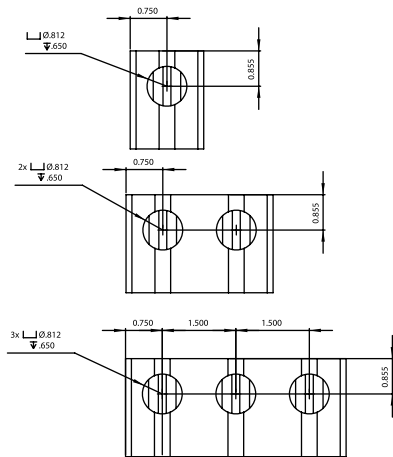

BUTT FASTENING

10 SERIES

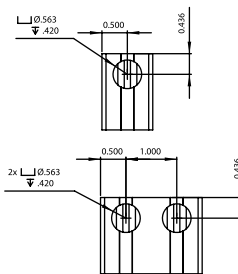

15 SERIES

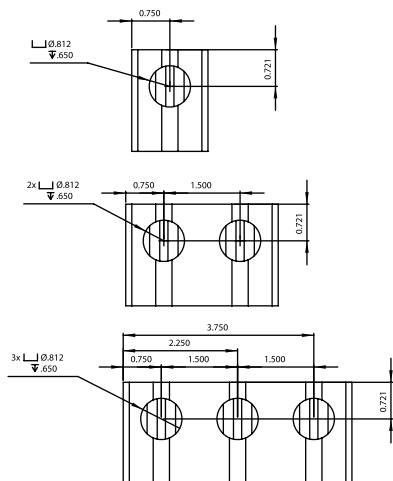

ORDERING NOTE

Counterboring requirements should be described by specifying:

1. The extrusion Item Number or Description
2. The quantity of extrusions
3. The machining service number
4. The end to be machined and the T-Slot location at which the counterbore is required
5. The length of the extrusion.

When multiple counterbores are needed on one profile, they should all be called out together, with a hyphen (-) separating each end / T-Slot location callout (see example). See page 11:02 for information regarding T-Slot location callouts.

EXAMPLE

A project requires that two lengths of profile be machined for an anchor fastener assembly. One of the lengths is the 1.5" x 1.5" @ 41" extrusion profile and requires the counterboring at one end only, in slot A1 and A3 of the profile. The other length is the 1.5" x 3" extrusion profile @ 45" that requires machining for two anchor fasteners at each end, in slot A3-A6 and B3-B6 of the profile only. The counterbore service would be ordered as follows:

ITEM #	QTY	MACHINING SERVICE #	LENGTH
650005 (TS 1515)	1	660106 A1/.75"-A1/44.25"	41"
650008 (TS 1530)	1	660020-A3-A6-B3-B6	45"
	1	660003	
	1	660006	
	6	660020	

(Counterbore machining services are priced per counterbore required.)

Machining Services

SLAM LATCH MACHINING

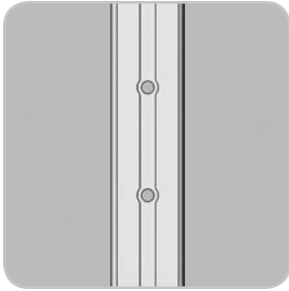

ITEM # DESCRIPTION
660170 Slam Latch Machining Service

- Slam latch is located on page 06:07.
- Same machining required on door and frame.

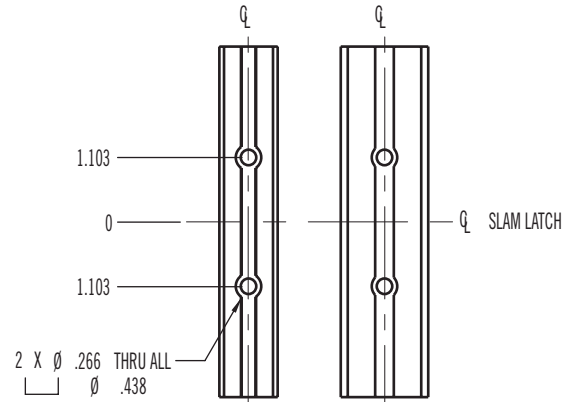

PANELS AND WIRE MESH - CUT TO SIZE

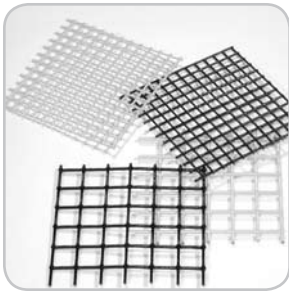

ITEM # DESCRIPTION
660062 Cutting Plastic Panels Any Side ≤ 48"
660063 Cutting Plastic Panels Any Side > 48"
660060 Shearing Expanded Metal Or Wire Any Side ≤ 48"
660061 Shearing Expanded Metal Or Wire Any Side > 48"

ORDERING NOTE

Panel saw cut requirements should be described by specifying the type of panel required and the size required in inches. Pricing is calculated on a square foot basis. The cutting charges will appear as a separate line item.

EXAMPLE

A machine guard project requires 3 clear Lexan® panels, Item number 655433, cut to a size of 4' x 3'. This panel would be ordered as follows:

ITEM #	QTY	MACHINING SERVICE #	PANEL SIZE
655433	3	660062 4' x 3'	36 sq. feet

» A cut to size machining service is available for polycarbonate panels, expanded PVC panels and wire mesh.

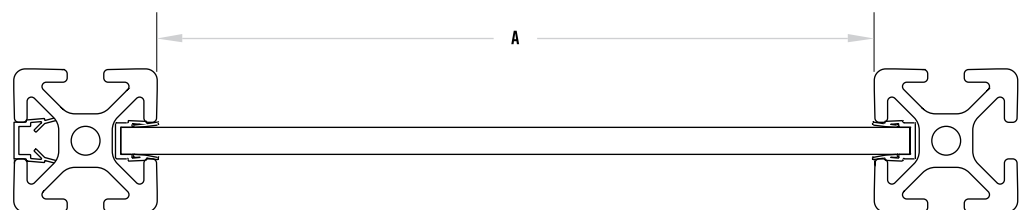

15 SERIES / 40 SERIES
TO CALCULATE HEIGHT,
ADD .75" TO "A"

10 SERIES / 25 SERIES
TO CALCULATE HEIGHT,
ADD .50" TO "A"

MITER SAW CUTS AND COUNTERBORE



Easy assembly miter cuts allow you to assemble without inserting fasteners through counterbore. The pre-assembled fastener and T-nut will slide into the mitered piece, ready to assemble.

For custom 45° support brackets and other types of brackets, a miter saw cut and counterbore machining service is required.

ITEM #	DESCRIPTION (for one end)
660039	Miter Cut 1010, 1010-QR / 2525
660041	Miter Cut 1020 / 2550
660042	Miter Cut 2020
660043	Miter Cut 1030
660044	Miter Cut 2040
660038	Miter Cut 1515, 1515-L, 1515-QR / 4040, 4040-L, 4040-VL
660046	Miter Cut 1530 & 1530-L / 4080, 4080-L, 4080-VL
660047	Miter Cut 1545
660054	Miter Cut 3030 / 8080
660055	Miter Cut & Counterbore 1030 / 2575

ITEM #	DESCRIPTION (for both ends)
660112	Easy Assembly Miter Cut & Counterbore 1010, 1010-QR / 2525
660113	Easy Assembly Miter Cut & Counterbore For 1020, 2020 / 2550
660114	Easy Assembly Miter Cut & Counterbore 1515, 1515-L, 1515-QR / 4040, 4040-L, 4040-VL
660115	Easy Assembly Miter Cut & Counterbore 1530, 1530-L, 3030 / 4080, 4080-L, 4080-VL, 8080
660116	Easy Assembly Miter Cut & Counterbore 1545
660050	Miter Cut & Counterbore 1010, 1010-QR / 2525
660053	Miter Cut & Counterbore 1020, 2020 / 2550
660049	Miter Cut & Counterbore 1515, 1515-L, 1515-QR / 4040, 4040-L, 4040-VL
660056	Miter Cut & Counterbore 1530, 1530-L, 3030 / 4080, 4080-L, 4080-VL, 8080
660058	Miter Cut & Counterbore 1545

RECOMMENDED FASTENERS

10S	651240	1/4-20 x 5/8" SHCS, Washer & Economy T-Nut
15S	651213	5/16-18 x 3/4" SHCS, Washer & Economy T-Nut
25S	651334 & 651386 & 651080	M6 x 16mm SHCS, Washer & Economy T-Nut
40S	651337 & 651367 & 651081	M8 x 20mm SHCS, Washer & Economy T-Nut

ORDERING NOTE

Miter cut and counterbore requirements should be described by specifying:

1. The extrusion Item number or Description
2. The quantity of extrusions to be machined
3. The machining service number
4. The end at which the machining is required and the face from which a bolt would be installed into the counterbore.

Also, indicate the length of the finished profile from longest corner to longest corner. To specify the correct face on a 15 x 30 extrusion profile (where there are multiple T-Slots), specify only one of the T-Slot locations on that face. See page 11:02 for information on the correct end and T-Slot callouts.

EXAMPLE - Miter Cut:

Two custom support brackets are required for your project, but you plan on counterboring the part yourself. You will use 15 x 30 extrusions that are 15" long from corner to corner. The machining service would look as follows:

ITEM #	QTY	MACHINING SERVICE #	LENGTH
650008	2	660046 A1-B1	15"

Machining Services

MITER SAW CUTS AND COUNTERBORE *(continued)*



EXAMPLE - Miter Cut & Counterbore:

A custom support bracket is required for your project. The 15 x 30 extrusion must be 20" long from corner to corner and must be machined from the same face at both ends. The machining service would look as follows:

ITEM #	QTY	MACHINING SERVICE #	LENGTH
650008	2	660046 A1-B1	15"

» For Standard Miter Cut Extrusions see page 06:24. Otherwise, miter cut services should be per supplied drawing.

NOTCH PANEL FOR EXTRUSION CLEARANCE

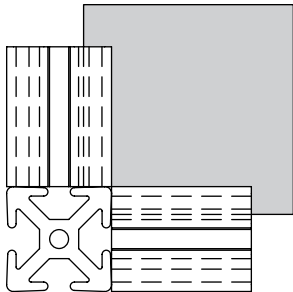

ITEM #	DESCRIPTION
660098	Notch Plastic Corner For 10 Series / 25 Series Extrusion Clearance / Notch
660099	Notch Plastic Corner For 15 Series / 40 Series Extrusion Clearance / Notch

Panel notching gives clearance for perpendicularly mounted extrusions. This machining service is only needed when panels are installed in TSLOTS.

DIMENSIONS	A
10/25 SERIES	.312
15/40 SERIES	.440

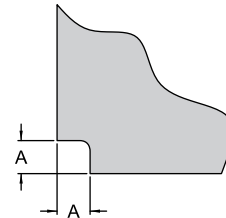

NOTCH PANEL FOR END FASTENER CLEARANCE

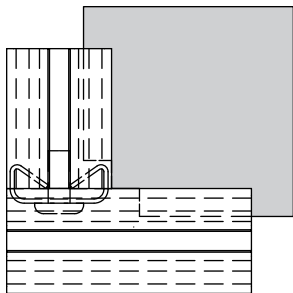

ITEM #	DESCRIPTION
660096	Notch Plastic For End Fastener 10 Series / 25 Series
660097	Notch Plastic For End Fastener 15 Series / 40 Series

Panel notching gives clearance for end fastener. This machining service is only needed when panels are installed in TSLOTS.

DIMENSIONS	A	B
10/25 SERIES	.250	.650
15/40 SERIES	.340	.650

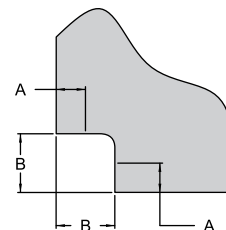

NOTCH PANEL FOR ANCHOR FASTENER CLEARANCE

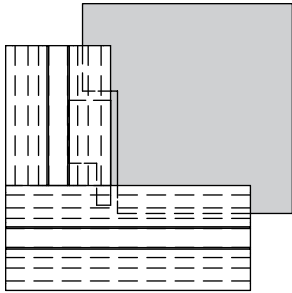

ITEM #	DESCRIPTION
660088	Anchor Fastener Notch For 10 Series / 25 Series
660089	Anchor Fastener Notch For 15 Series / 40 Series

Panel notching gives clearance for anchor fastener. This machining service is only needed when panels are installed in TSLOTS.

DIMENSIONS	A	B
10/25 SERIES	.375	1.063
15/40 SERIES	.500	1.750

Panel should be installed after the anchor fastener is tightened.

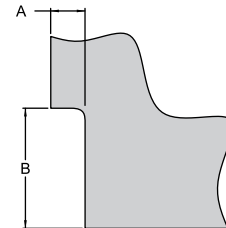

EDGE RADIUS FOR PLASTIC PANELS

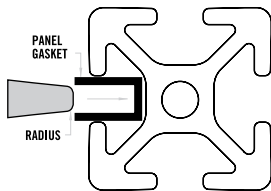

ITEM #	DESCRIPTION
660094	Edge Radius 3/16" or 1/4" Plastic Panels all sides < 48"
660095	Edge Radius 3/16" or 1/4" Plastic Panels any side > 48"

- Round off sharp edges of highly visible panels.
- Allows for easy insertion of panels into panel gasket, on page 06:13.

» See page 06:20 for Plastic Panels.